



EMC



ELHY®

**ELECTRO HYDRAULIC
THRUSTERS**

THE ORIGINAL. BE SAFE.

TEINCO
INDUSTRIAL

EMC.moving ahead.

DESIGN, FUNCTION AND ADVANTAGES

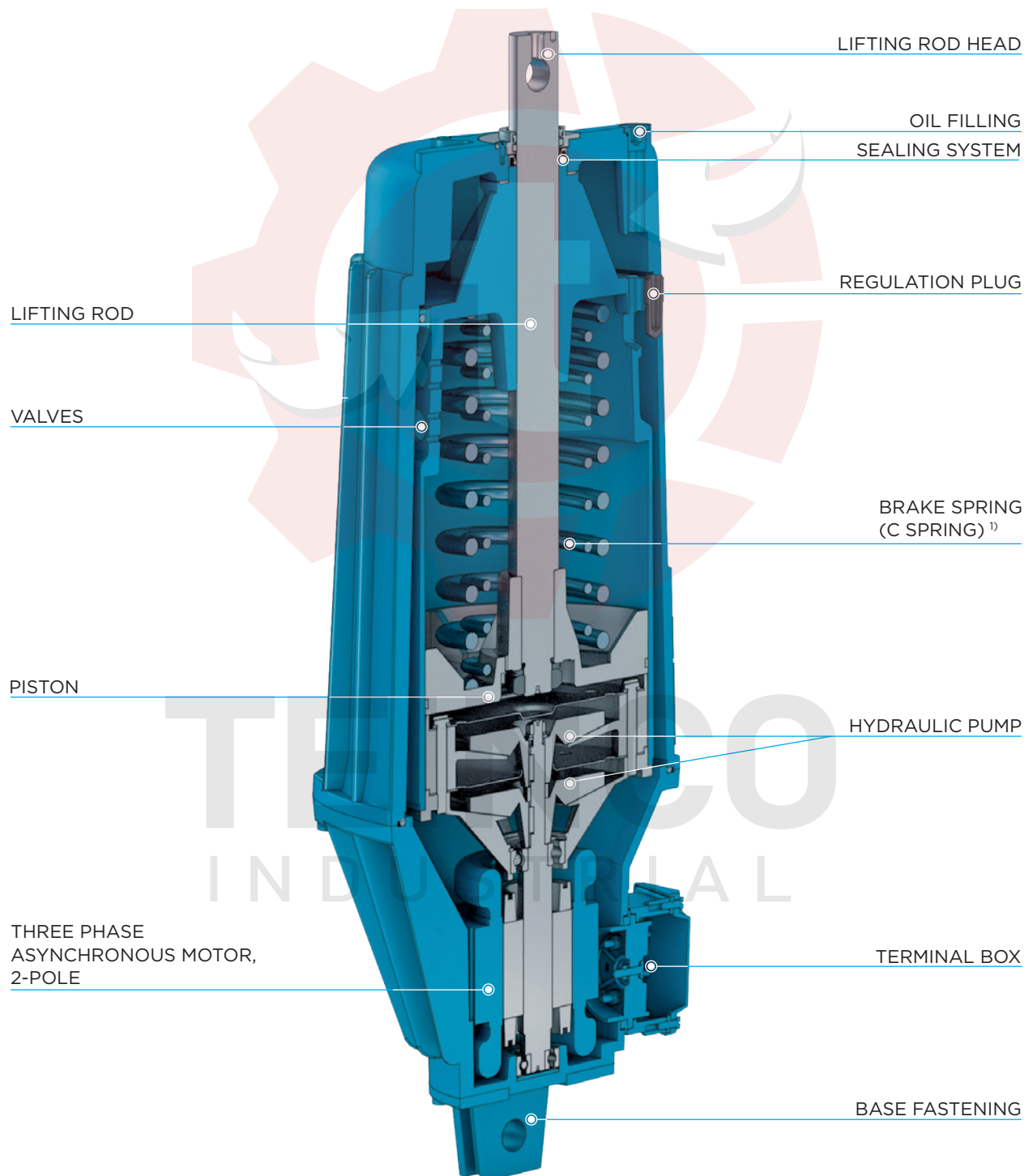

¹⁾ auxiliary equipment

ELHY®-SERIES EB

AREA OF APPLICATION

In addition to a wide range of applications in the mechanical engineering industry, materials lifting and handling can be considered as the main uses of industrial brakes offered on the market. Drive and brake problems can be solved using a drum brake or a shoe brake which is still quite common or by using industrial type disk brakes.

As the requirements with respect to driving power, controllability and availability have clearly increased, advanced electrical engineering and electronics have become ever more important catering for these demands. Although most components of modern systems are electrical and electronic, the mechanical safety brake, with the electrohydraulic ELHY® brake thruster, still has the most important role to play: as the last link in the chain, it ensures safety for man and machine in the event of power failure.

TECHNICAL VALUES

Type Standard	Lifting force [N]	Stroke path [mm]**	Power consumption [W]	Current consumption [A] at 400 V 50 Hz	Switching frequency with S3 operation [c/h]	Weight [kg]
EB 12/...	220	50	160	0.4	2000	12
EB 20/...	300	50	180	0.4	2000	11
EB 50/...	500	50 - 100	200	0.4	2000	14 - 15*
EB 80/...	800	60 - 160	300	0.5	2000	19 - 26*
EB 125/...	1250	60 - 160	400	0.7	2000	19 - 26*
EB 150/...	1500	60 - 160	400	0.7	2000	19 - 26*
EB 250/...	2500	60 - 160	500	0.9	2000	33 - 40*
EB 320/...	3200	100	600	1.1	2000	40
EB 630/...	6300	120	850	1.6	240	45

Type DIN	Lifting force [N]	Stroke path [mm]**	Power consumption [W]	Current consumption [A] at 400 V 50 Hz	Switching frequency with S3 operation [c/h]	Weight [kg]
EB 220-...	220	50	160	0.4	2000	12
EB 300-...	300	50	180	0.4	2000	11
EB 500-...	500	60 - 120	200	0.4	2000	14 - 15*
EB 800-...	800	60 - 120	300	0.5	2000	19 - 25*
EB 1250-...	1250	60 - 120	400	0.7	2000	26
EB 2000-...	2000	60 - 120	500	0.8	2000	33 - 40*
EB 3000-...	3000	60 - 120	600	0.9	2000	40
EB 6300-...	6300	120	850	1.6	240	45

* depending on stroke path

** further on request

Stroke work (N cm) = Lifting force x stroke path

EB STANDARD

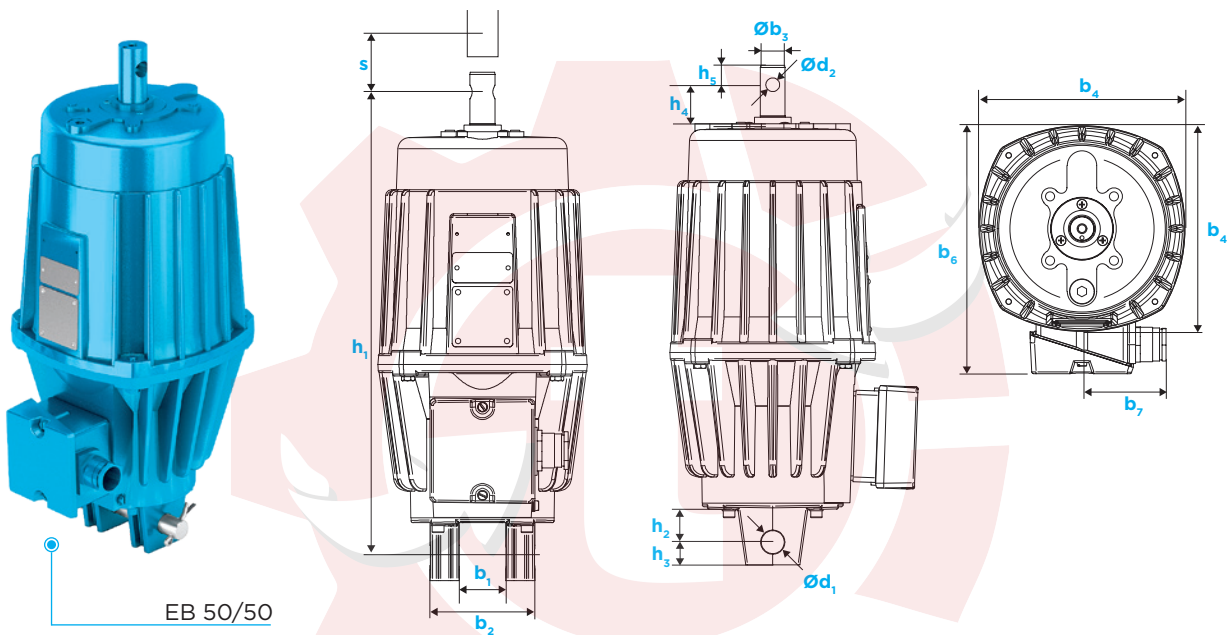

Size	Type	s	b ₁ +2	b ₂ +1	b ₃ e8	b ₄	b ₆	b ₇	d ₁ +0,1	d ₂ F9	h ₁ +/-1	h ₂	h ₃ +1	h ₄ +/-1	h ₅
0	EB 12 -1 ¹⁾	50	-	-	20	162	236	100	16.1	12	272	-	-	23	17
	EB 12 -2 ²⁾	50	40	80	20	162	236	100	16.1	12	286	20	16	23	17
	EB 12 -3 ³⁾	50	40	80	20	162	236	100	16.1	12	314	38	16	23	17
1	EB 20	50	40	80	21,5	150	200	100	20.2	12	380	30	20	30	17
	EB 50	50	40	90	21,5	180	220	100	20.2	12	400	30	20	32	17
2	EB 50	100	40	90	21,5	180	220	100	20.2	12	452	30	20	32	17
	EB 80, 125, 150	60	40	90	27,5	208	232	100	20.2	16	458	30	25	36	21
3	EB 80, 125, 150	160	40	90	27,5	208	232	100	20.2	16	573	30	25	36	21
	EB 250	60	40	90	35,5	250	265	100	20.2	20	549	30	25	36	25
4	EB 250	160	40	90	35,5	250	265	100	20.2	20	660	30	25	36	25
	EB 320	100	40	90	35,5	250	265	100	20.2	20	660	30	25	36	25
5	EB 630	120	40	90	35,5	250	265	100	20.2	20	660	30	25	36	25

¹⁾ Flange version

²⁾ Basic unit with cast-on feet

³⁾ Unit with screwed foot plate

ELECTRO HYDRAULIC THRUSTERS **ELHY**[®]

EB DIN

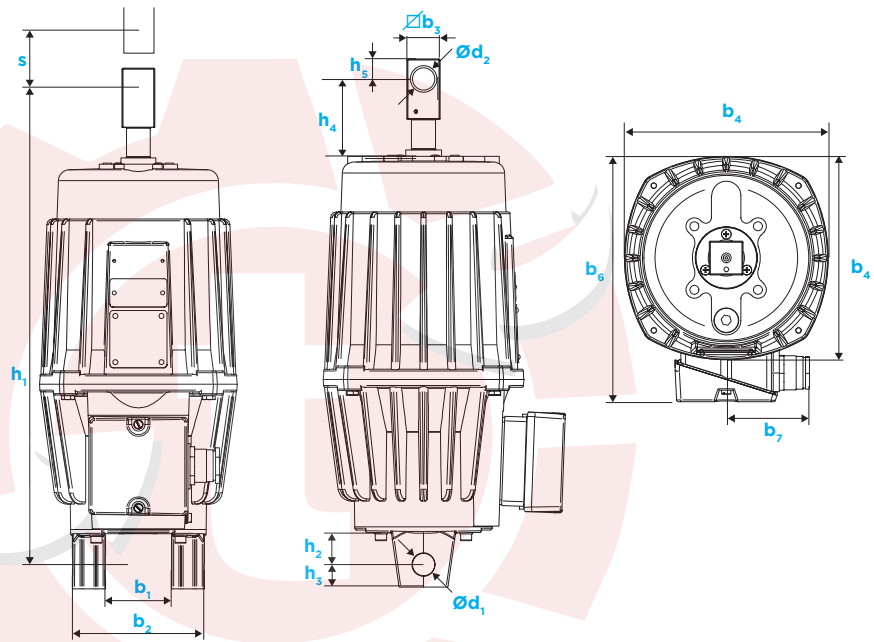

Size	Type	s	b_1 +2	b_2 +1	b_3 e8	b_4	b_6	b_7	d_1 +0,1	d_2 F9	h_1 +/-1	h_2	h_3 +1	h_4 +/-1	h_5
0	EB 120 -2 ²⁾	40	25	45	20	110	178	55	12.1	12	265	12	14	20	10
	EB 120 -3 ³⁾	40	40	60	20	110	178	55	16.1	12	286	16	23	20	10
	EB 220 -1 ¹⁾	50	-	-	20	162	236	100	16.1	12	272	-	-	26	15
	EB 220 -2 ²⁾	50	40	80	20	162	236	100	16.1	12	286	20	16	26	15
	EB 220 -3 ³⁾	50	40	80	20	162	236	100	16.1	12	314	38	16	26	15
1	EB 300	50	40	80	25	150	200	100	16.1	16	370	18	16	32	15
2	EB 500	60	60	120	30	180	220	100	20.1	20	435	30	20	67	18
	EB 500	120	60	120	30	180	220	100	20.1	20	515	30	20	95	18
3	EB 800	60	60	120	30	208	232	100	20.1	20	458	23	22	42	18
	EB 800	120	60	120	30	208	232	100	20.1	20	530	23	22	39	18
	EB 1250	60	40	90	40	208	232	100	25.1	25	645	30	25	108	25
	EB 1250	120	40	90	40	208	232	100	25.1	25	705	30	25	168	25
4	EB 2000	60	40	90	40	250	265	100	25.1	25	645	30	25	132	25
	EB 2000	120	40	90	40	250	265	100	25.1	25	705	30	25	81	25
	EB 3000	60	40	90	40	250	265	100	25.1	25	660	30	25	36	25
	EB 3000	120	40	90	40	250	265	100	25.1	25	705	30	25	81	25
5	EB 6300	120	40	90	40	250	265	100	25.1	25	705	30	25	83	25

Special versions according to DIN 15430

Size	Type	s	b_1 +2	b_2 +1	b_3 e8	b_4	b_6	b_7	d_1 +0,1	d_2 F9	h_1 +/-1	h_2	h_3 +1	h_4 +/-1	h_5
2	EB 320	50	40	80	25	180	220	100	16.1	16	385	18	16	30	18
	EB 320	100	40	80	25	180	220	100	16.1	16	493	18	16	85	18
	EB 500	50	60	120	30	180	220	100	20.1	20	435	30	20	65	18
	EB 500	100	60	120	30	180	220	100	20.1	20	515	30	20	95	18
3	EB 800	160	60	120	30	208	232	100	20.1	20	573	23	22	42	18
	EB 1250	160	40	90	40	208	232	100	25.1	25	705	30	25	168	25
	EB 1500	60	40	90	40	208	232	100	25.1	25	645	30	25	108	25
4	EB 1500	160	40	90	40	208	232	100	25.1	25	705	30	25	168	25
	EB 2500	60	40	90	40	250	265	100	25.1	25	645	30	25	152	25
	EB 2500	160	40	90	40	250	265	100	25.1	25	705	30	25	81	25
	EB 3200	100	40	90	40	250	265	100	25.1	25	660	30	25	36	25

¹⁾ Flange version

²⁾ Basic unit with cast-on feet

³⁾ Unit with screwed foot plate

ELECTRICAL VERSION

MOTOR

- Three-phase asynchronous motor, 2-pole
- For power data see "Technical values"
- Standard insulation per insulation class F
- Special version in insulation class H

VOLTAGES AND FREQUENCIES

- Standard:
 - 230/400 V, 50 Hz, 3 ~
 - 290/500 V, 50 Hz, 3 ~
 - 400/690 V, 50 Hz, 3 ~
- Special versions 110 V to 690 V, 3 ~, 50 Hz and 60 Hz possible
- All devices are star (Y) connected on delivery
- Alternating current versions (with capacitor for Steinmetz circuit) on request

CABLE INLET

- Threaded cable gland M 25 x 1.5 for cable cross-sections to 4 x 2.5 mm² (Ø 7.5 - 18 mm)

OPERATING MODES

- Continuous operation S1 and intermittent duty S3 - 60 % duty cycle standard
- With ambient temperatures > 50 °C deviating technical values (available on request)

TERMINAL BOX

- Terminal board 6-pole, with devices with position indicator Lk/La 3-pole
- Supply line connection M5
- Internal protective conductor connection: M5
- External protective conductor connection: M5
- Connection Lk/La: M4

MECHANICAL VERSION

INSTALLATION VARIANTS

- The base fastening can be mounted offset through 90°.
- The lifting rod head at the top rotates in all types.
- In case of versions with a limit switch, minor modifications are required in order to rotate the pressure strap or fasten the base as required.

OPERATING FLUID

- Mineral hydraulic oil or silicone oil depending on the operating conditions, e.g. ambient temperature, factory-filled

ENCLOSURE

- Standard IP 56, in special version up to IP 66

PAINT APPLICATION PER DIN EN ISO 12944

- 2K Polyacryl coating, layer thickness 80 µm
- Special paint up to corrosion load C5-M, layer thickness up to 240 µm
- Standard colour RAL 5008 (grey-blue)

PROTECTIVE MEASURES

- Redundant dust protection seal
- Redundant seal with the hydraulic chamber
- Piston rod QPQ
- Protective tube against external mechanical influences

ELECTRICAL & MECHANICAL AUXILIARY EQUIPMENT

LIFTING, LOWERING OR THROTTLING VALVE (H, S, D)

- With a built-in lift, lowering or throttling valve, lifting or lowering times as well as both times can be infinitely increased. The adjustable minimum values attain 10 to 20-times the normal values
- Integrated valves in "open position" result in an extension of the lifting and lowering times with short stroke thrusters of up to approx. 0.4 to 1.0 seconds, and with long stroke thrusters of up to approx. 0.7 to 2.0 seconds.
- The desired lifting or lowering time is set externally on the device in standing position.

QUICK LOWERING SWITCHING

- The lowering times are shortened through the use of three-phase motor capacitors, or by short-circuiting the stator winding via a contactor.
- The lowering times reduce by approx. 15 %.

INCREASED CORROSION PROTECTION

- Increased corrosion protection is necessary with the use of ELHY® devices in environments of aggressive media and/or high relative humidity with the resultant formation of condensation.
- Increased protection in the motor:**
The motor compartment is under oil and does not require any additional corrosion protection.
- Increased external protection:**
Through special paint application, see "Mechanical version"

CONTROL/DAMPING SPRING (R/D-SPRING)

- Damping of the load change when closing and opening the brake.
- The R/D-spring is only effective in conjunction with a C-spring.
- The installation length "h1" of the device does not change.
- When setting the working point of the brake, the spring characteristic must be taken into account.
- Main application: ELHY® control brake

BRAKE SPRING (C-SPRING)

- Integrated C-spring for generating the brake force. The specified brake force of the C-spring is reached at 0...maximum of the nominal stroke.

VERSIONS WITH BRAKE SPRING

Type STANDARD	Brake spring force (c-spring) N]
EB 12/50 C12	110 - 160
EB 20/50 C20	220 - 260
EB 50/50 C32	370 - 450
EB 50/50 C50	540 - 680
EB 80/60 C80	740 - 1060
EB 125/60 C125	1200 - 1630
EB 150/60 C125	1200 - 1630
EB 250/60 C200	1900 - 2500
EB 320/100 C320	2540 - 3690
Type DIN	Brake spring force (c-spring) N]
EB 220-50 C220	200 - 290
EB 300-50 C270	260 - 310
EB 500-60 C500	540 - 680
EB 800-60 C800	740 - 1060
EB 1250-60 C1250	1200 - 1630
EB 2000-60 C2000	1900 - 2500
EB 3000-60 C3200	2540 - 3690

