

SAFEMASTER
Interface Modules
LG 3096, MK 3096N

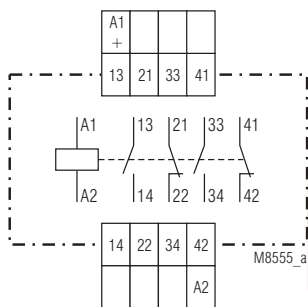

- With **forcibly guided** contacts according to IEC 61810-3
- Max. 6 contacts
- As option goldplated contacts to switch low loads
- Wire connection: also 2 x 1.5 mm² stranded ferruled, or 2 x 2.5 mm² solid DIN 46 228-1/-2/-3/-4
- As option with pluggable terminal blocks for easy exchange of devices
 - with screw terminals
 - or with cage clamp terminals
- Width 22.5 mm

Circuit Diagrams



LG 3096.52
MK 3096N.52

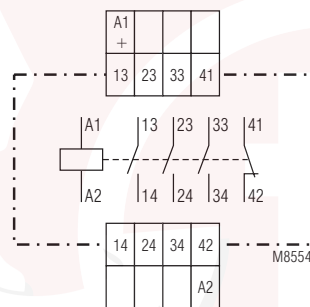

LG 3096.48
MK 3096N.48

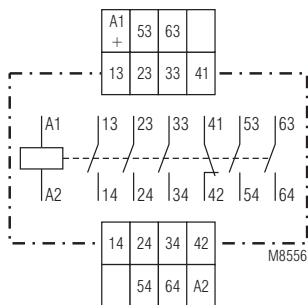

LG 3096.60
MK 3096N.60

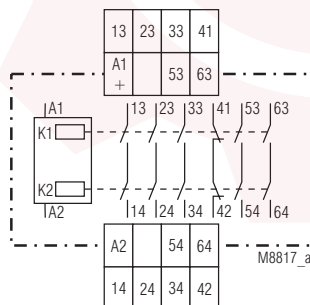

MK 3096N.60/100

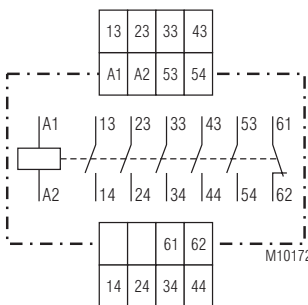

LG 3096.60/300

Approvals and Markings



* see variants

Application

- Switching device with the possibility to monitor the contact status via forcibly guided NC contacts.

Connection Terminals

Terminal designation	Signal description
A1 / A2	Supply voltage
13, 14, 23, 24, 33, 34, 43, 44, 53, 54, 63, 64	Forcibly guided NO contacts
21, 22, 41, 42, 61, 62	Forcibly guided NC contacts

Technical Data

Input

Nominal voltage U_N :

LG 3096: DC 24, 48 V; AC 100, 230 V

MK 3096: DC 24, 48 V

Voltage range: 0.8... 1.1 U_N

Nominal consumption 0.6 W

Output

Contacts:

MK 3096.52, LG 3096.52: 2 NO and 2 NC contacts

MK 3096.48, LG 3096.48: 3 NO and 1 NC contacts

MK 3096.60, LG 3096.60: 5 NO and 1 NC contacts

Contact type: forcibly guided

Operate time: typical 20 ms

Release time: typical 15 ms

Nominal output voltage: AC 250 V

Thermal current I_{th} 5 A

Switching capacity

to AC 15

NO contacts: 3 A / AC 230 V IEC/EN 60 947-5-1

NC contacts: 2 A / AC 230 V IEC/EN 60 947-5-1

to DC 13

NO contacts: 1 A / DC 24 V IEC/EN 60 947-5-1

NC contacts: 1 A / DC 24 V IEC/EN 60 947-5-1

to DC 13

(switching frequency: 0.1 Hz): 0,5 A / DC 110 V

4 A / DC 24 V

2 contacts in series: 1 A / DC 110 V

MK 3096N/100: 1 A / DC 110 V

2 contacts in series: 4 A / DC 110 V

Electrical life

IEC/EN 60 947-5-1

NO contacts:

to AC 15 at 3 A, AC 230 V: 1.5×10^5 switching cycles

NO contacts:

to AC 15 at 2 A, AC 230 V: 3×10^5 switching cycles

NC contacts:

to AC 15 at 2 A, AC 230 V: 1×10^5 switching cycles

Permissible switching

frequency: 10 switching cycles / s

Switching voltage min./max.: AC/DC 10 V / DC 250 V, AC 400 V

Switching current min./max.: 10 mA / 5 A

Switching capacity min./max.: 3 VA / 1250 VA

3 W / 200 W

Short circuit strength

max. fuse rating:

LG 3096: 10 A gL IEC/EN 60 947-5-1

MK 3096N: 10 A gL IEC/EN 60 947-5-1

Mechanical life: $\geq 20 \times 10^6$ switching cycles

General Data

Operating mode:

Continuous operation

Temperature range:

Operation: - 20 ... + 60°C

Storage: - 40 ... + 60°C

Altitude: < 2.000 m

Clearance and creepage distances

rated impulse voltage / pollution degree: 4 kV / 2 IEC 60 664-1

EMC

Electrostatic discharge: 8 kV (air) IEC/EN 61 000-4-2

HF irradiation: 10 V / m IEC/EN 61 000-4-3

Fast transients: 4 kV IEC/EN 61 000-4-4

Surge voltages

between

wires for power supply: 2 kV IEC/EN 61 000-4-5

between wire and ground: 4 kV IEC/EN 61 000-4-5

Interference suppression: Limit value class B EN 55 011

Degree of protection

Housing: IP 40 IEC/EN 60 529

Terminals: IP 20 IEC/EN 60 529

Housing: Thermoplastic

Vibration resistance: Amplitude 0.35 mm, frequency 10 ... 55 Hz, IEC/EN 60 068-2-6

Technical Data

Climate resistance: 20 / 060 / 04 IEC/EN 60 068-1

Terminal designation: EN 50 005

Wire connection DIN 46 228-1/-2/-3/-4

Screw terminals (integrated): 1 x 4 mm² solid or
1 x 2.5 mm² stranded ferruled (isolated)
or
2 x 1.5 mm² stranded ferruled (isolated)
or 2 x 2.5 mm² solid

Insulation of wires
or sleeve length: 8 mm

Plug in with screw terminals

max. cross section
for connection: 1 x 2.5 mm² solid or
1 x 2.5 mm² stranded ferruled (isolated)

Insulation of wires
or sleeve length: 8 mm

Plug in with cage clamp terminals

max. cross section
for connection: 1 x 4 mm² solid or
1 x 2.5 mm² stranded ferruled (isolated)

min. cross section
for connection: 0.5 mm²

Insulation of wires
or sleeve length: 12 ± 0.5 mm

Wire fixing: Plus-minus terminal screws M 3.5
box terminals with wire protection or
cage clamp terminals

Fixing torque: 0.8 Nm

Mounting: DIN rail IEC/EN 60 715

Weight 160 g

Dimensions

Width x height x depth

LG 3096: 22.5 x 90 x 121 mm

LG 3096 PC: 22.5 x 111 x 121 mm

LG 3096 PS: 22.5 x 104 x 121 mm

MK 3096N: 22.5 x 90 x 102 mm

MK 3096N PC: 22.5 x 111 x 102 mm

MK 3096N PS: 22.5 x 104 x 102 mm

Classification to DIN EN 50155 for MK 3096N

Vibration and

shock resistance: Category 1, Class B IEC/EN 61 373

Protective coating of the PCB: No

CSA-Data for LG 3096

Switching capacity: 3A 250Vac

Wire connection: 60°C / 75°C copper conductors only

Fixed screw terminal: AWG 20 - 12 Sol/Str Torque 0.8 Nm

Plug in screw terminal: AWG 20 - 14 Sol Torque 0.8 Nm

AWG 20 - 16 Str Torque 0.8 Nm

Plug in cage clamp terminal: AWG 20 - 12 Sol/Str Torque 0.8 Nm

Info Technical data that is not stated in the CSA-Data, can be found in the technical data section.

CCC-Data for MK 3096N

Thermal current I_{th} : 4 A

Switching capacity

to AC 15: 1,5 A / AC 230 V IEC/EN 60 947-5-1

to DC 13: 1 A / DC 24 V IEC/EN 60 947-5-1

Info Technical data that is not stated in the CCC-Data, can be found in the technical data section.

Standard Types

LG 3096.60 DC 24 V

Article number: 0056147
 • Output: 5 NO and 1 NC contacts
 • Width: 22.5 mm

MK 3096N.60 DC 24 V

Article number: 0055931
 • Output: 5 NO and 1 NC contacts
 • Width: 22.5 mm

Variants

LG 3096.__/004

MK 3096N.__/004: With gold plated contacts to switch low loads.
 Because of the gold plated contacts the MK 3096N.__/004, LG 3096.__/004 can be used to switch small loads 1 mVA ... 7 VA, 1 mW ... 7 W in the range of 0.1 ... 60 V, 1 ... 300 mA. The gold plated contacts allow also to switch the maximum current but the gold plating will be burnt off. After that the contacts cannot be used any more to switch the small loads.

LG 3096.__/300:

LG 3096.__/304:

LG 3096.__/___/60:

AC-units
 AC-units with gold plated contacts with CSA-approval (Canada/USA), on request

MK 3096N/100:

2 contacts switched internally in series.

MK 3096N:

with CCC-approval on request

Ordering example for variants

MK 3096N. PS/ DC 24 V

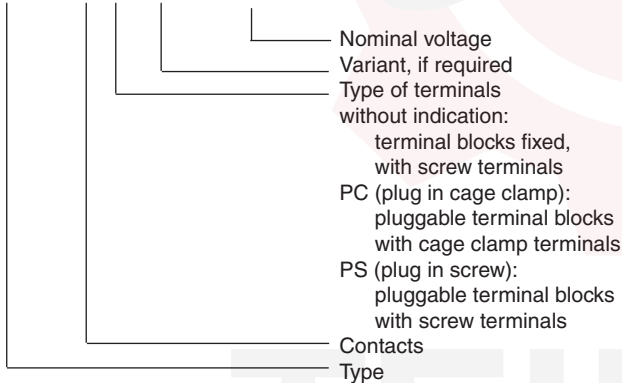

Options with Pluggable Terminal Blocks

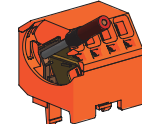
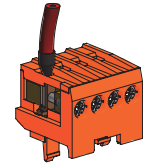
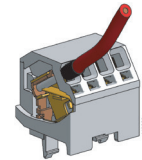
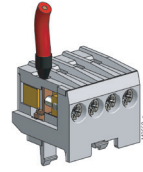

Screw terminal
 (PS/plugin screw)

Cage clamp terminal
 (PC/plugin cage clamp)

Notes

Removing the terminal blocks with cage clamp terminals

1. The unit has to be disconnected.
2. Insert a screwdriver in the side recess of the front plate.
3. Turn the screwdriver to the right and left.
4. Please note that the terminal blocks have to be mounted on the belonging plug in terminations.

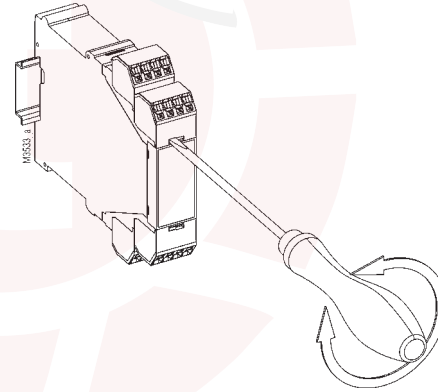

Characteristic

