

Turbine Fuel Shut Off Valve

Model 4420E

Typical applications

Developed for use in manual and automatic control systems:

- Fuel shut off valve for gas turbines in the 10 - 30 MW size range
- Starting air/gas valve
- Vented fuel/gas valve

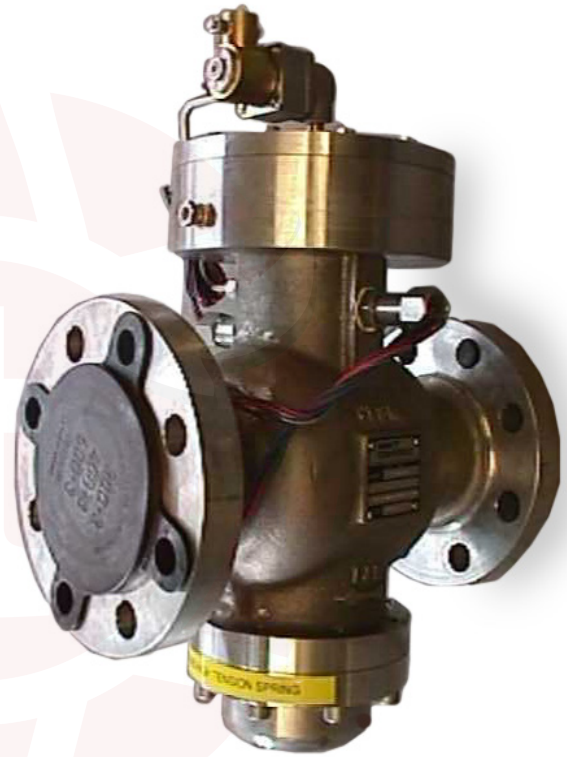



Model 4420 Turbine Fuel Shut Off Valve

Key features and benefits

- Less than 100 millisecond close time
- Unique "vent" port
 - No need for separate bleed valves
 - Reduced installation cost
- 2-way and 2-way vented options
- Open, Closed, or Open/Closed position switch indication (optional)

Accreditations available

- PED/ PE(S)R Suitable for Group 1 & 2 gases
(Ensure materials are compatible)
- ATEX/ UKEX  II 2G Ex h IIC T6...T2 Gb X
-  Complies with all relevant EU directives
- UKCA Complies with all relevant UK statutory requirements
- NACE MR0175
- ISO 15156

amot

www.amot.com

Turbine Fuel Shut Off Valve - Model 4420E

Overview

The Model 4420 has been specifically designed as a fuel shutoff valve in gas turbine applications. Its compact size and quick close time make it ideal for use in gas turbines in the 10 - 30 MW range.

The 4420 is a stainless steel, single acting, spring return, pneumatically actuated valve and is available in both 2-way and 2-way vented versions.

Operation

2-way vented version

When pressure is applied to the pilot port, the valve is opened to allow flow to travel from the IN port to the OUT port. The VENT port is closed. When the pilot pressure is released, the IN port closes while the VENT port opens to the OUT port. This venting relieves pressure within the valve and in the down stream piping.

The 2-way vented version is ideal for gas turbine applications because, upon shutdown, it relieves and vents pressure on the down stream side. This action eliminates the need for a separate bleed valve, providing a cost savings and simplified piping.

2-way version

When pressure is applied to the pilot port, the valve is opened to allow the flow to travel from the IN port to the OUT port. When the pilot pressure is released, a spring closes the main ports.

Flow Charts

Flow coefficient

Flow coefficient (calculated)		
Size	Kv	Cv
2"	72	83
3"	112	130

$$Kv = 0.865 Cv$$

$$Cv = 1.156 Kv$$

Cv is the imperial coefficient. It is defined as the flow rate in Cubic Feet per Hour (ft³/hr) of air at a temperature of 60° Fahrenheit with a pressure drop across the valve of 1 psi. The basic formula to find a valve's Cv is shown below:

$$Cv = \frac{Q}{1360} \sqrt{\frac{SG(^{\circ}F+460)}{P_{up} DP}}$$

$$Q = 1360 Cv \sqrt{\frac{P_{up} DP}{SG(^{\circ}F+460)}}$$

$$DP = \left[\frac{Q}{1360 Cv} \right]^2 \left[\frac{SG(^{\circ}F+460)}{P_{up}} \right]$$

Q = Flow in ft³/hr

DP = Pressure drop (psi)

P_{up} = Valve supply pressure (psi)

SG = Specific gravity of gas
(Natural Gas = 0.65 @ 250°F)

Cv = Valve flow coefficient (English units)

°F = Temperature in °F

Turbine Fuel Shut Off Valve - Model 4420E

Valve Characteristics

Switch options

Code	Description	Approvals
N	None	
E	Open	CSA Class I, Div. 1, Groups C,D
F	Closed	
G	Open/Closed	
H	Open	UL Class I, Div. 1, Groups C,D
J	Closed	
K	Open/Closed	
P	Open	ATEX II 2G Ex db IIC T6 Gb or II 2G Ex db IIC T3 Gb
Q	Closed	
R	Open/Closed	

Pilot solenoid options

Code	Description	Approvals
00	None	
02	3-way QE solenoid, SS, 24VDC	UL/CSA Class I, Div. 1, Groups C & D
03	3-way QE solenoid, SS, 120VDC	
04	3-way QE solenoid, SS, 24VDC, QE5	
05	3-way QE solenoid, SS, 120VDC, QE5	
06	3-way QE solenoid, SS, 24VDC, 1301F Regulator	
07	3-way QE solenoid, SS, 120VDC, 1301F Regulator	
08	3-way QE solenoid, SS, 24VDC, QE5, 1301F Regulator	
09	3-way QE solenoid, SS, 120VDC, QE5, 1301F Regulator	
10	3-way QE solenoid, SS, 24VDC	
11	3-way QE solenoid, SS, 115VDC	
12	3-way QE solenoid, SS, 24VDC, QE5	
13	3-way QE solenoid, SS, 115VDC, QE5	
14	3-way QE solenoid, SS, 24VDC, 1301F Regulator	
15	3-way QE solenoid, SS, 115VDC, 1301F Regulator	
16	3-way QE solenoid, SS, 24VDC, QE5, 1301F Regulator	
17	3-way QE solenoid, SS, 115VDC, QE5, 1301F Regulator	
20	4-way solenoid, SS, 24VDC	UL/CSA Class I, Div. 1, Groups C & D
21	4-way solenoid, SS, 120VDC	
22	4-way solenoid, SS, 24VDC, QE5	
23	4-way solenoid, SS, 120VDC, QE5	
24	4-way solenoid, SS, 24VDC, 1301F Regulator	
25	4-way solenoid, SS, 120VDC, 1301F Regulator	
26	4-way solenoid, SS, 24VDC, QE5, 1301F Regulator	
27	4-way solenoid, SS, 120VDC, QE5, 1301F Regulator	

Turbine Fuel Shut Off Valve - Model 4420E

How to Order

Use the table below to select the unique specification of your Model 4420 Turbine Fuel Shut Off Valve.

Example	4420E	D	H	4	K	02	-AA	Code description
								Basic model (A)
Basic model (A)	4420E							316 stainless steel housing
								Valve size and type (B)
Valve size and type (B)		A						2", 2-way
		B						2", 2-way vented
		C						3", 2-way
		D						3", 2-way vented
								Connection code (C)
Connection code (C)			K					600 lb. ANSI RF
			H					300 lb. ANSI RF
								Internal material code (D)
Internal material code (D)				4				316 stainless steel spool / PTFE seals / Viton seals
								Switch options (E)
Switch options (E)					*			For switch options available, refer to the switch options table on page 6.
								Pilot solenoid options (F)
Pilot solenoid options (F)						**		For pilot solenoid options available, refer to the pilot solenoid options table on page 6.
								Customer special requirements (G)
Customer special requirements (G)							-AA	Standard (may be omitted)
							-***	Made-to-order

Specification

		Metric units	English units
Body and trim material	316 stainless steel		
Seal material	Viton		
Maximum pressure	Class 600 lb RF flanges	69 bar @ 38°C	1,000 psi @ 100°F
	Class 300 lb RF flanges	50 bar @ 38°C	720 psi @ 100°F
Temperature		-29°C - 204°C	-20°F - 400°F
Pilot pressure to actuate		4.1 - 10.3 bar	60 - 150 psi
Connections	2" valve	ANSI Class 300 or 600 RF flange	
	3" valve	ANSI Class 300 or 600 RF flange	
	Vent port	½" NPT	
	Solenoid/position switch conduit	½" NPT	
	Solenoid inlet port	¼" NPT	
Flow coefficient	2" valve	Cv = 83	Kv = 72
	3" valve	Cv = 130	Kv = 112
Close time*	Less than 100 ms		
Seat leakage	ANSI Class VI		
Pressure Equipment Directive, PED Pressure Equipment(Safety) Regulations, PE(S)R	Category 4, Suitable for group 1 & 2 gas		
Position switch ratings	UL or CSA Class I, Div. 1, Groups A, B, C, D		
Solenoid valve ratings	UL & CSA Class I, Div. 1, Type H Coil (24 VDC)		
Net weight	2"	38 kg	85 lbs
	3"	61 kg	135 lbs

European certified position switch and solenoid available by request.

* Contact AMOT for advice on suitable solenoid valves and pilot pressures.

Turbine Fuel Shut Off Valve - Model 4420E

Dimensions

Dimensions - inches (mm)

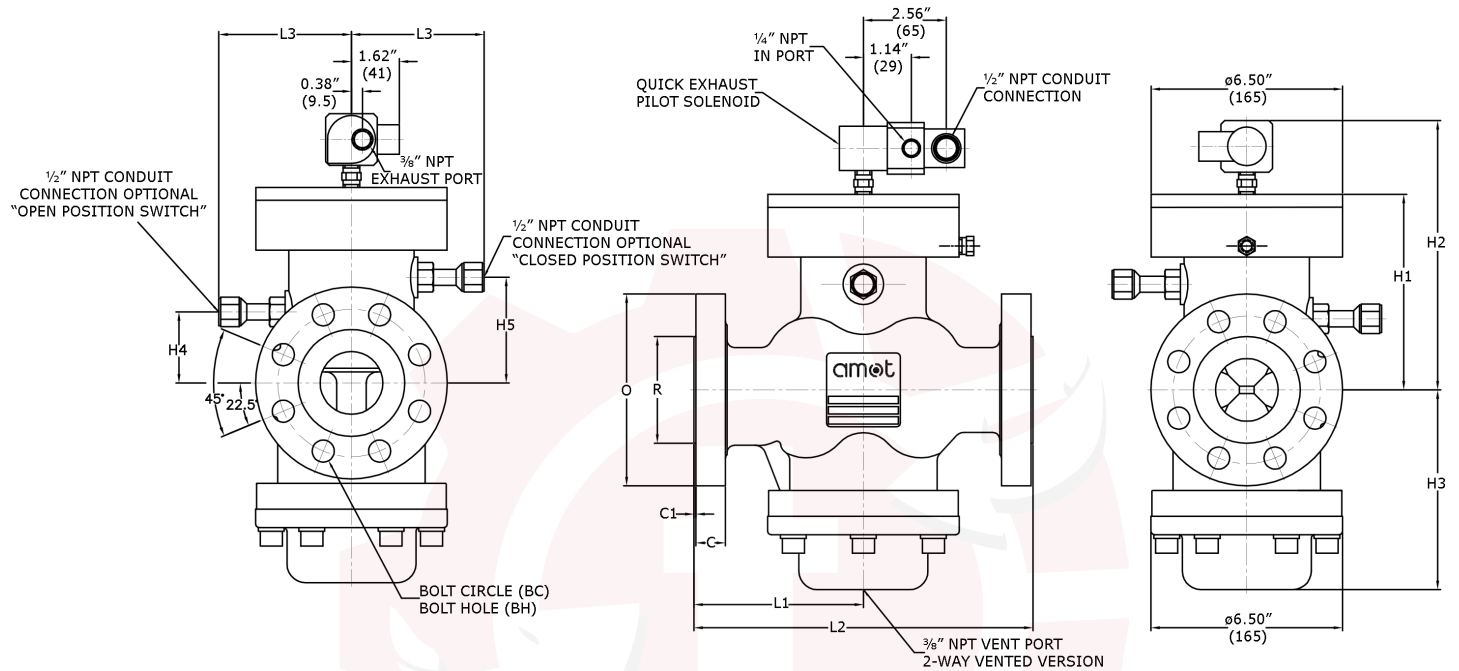

Flange connections

Dimension	2" 300 lb.		2" 600 lb.		3" 300 lb.		3" 600 lb.	
	Inches	mm	Inches	mm	Inches	mm	Inches	mm
L1	5.75"	146	5.75"	146	7.0"	178	7.0"	178
L2	11.5"	292	11.5"	292	14.0"	356	14.0"	356
L3	4.5"	114	4.5"	114	4.5"	114	4.5"	114
H1	6.62"	168	6.62"	168	7.75"	197	7.75"	197
H2	9.12"	232	9.12"	232	10.25"	260	10.25"	260
H3	6.78"	172	6.78"	172	7.25"	184	7.25"	184
H4	2.41"	61	2.41"	61	3.16"	80	3.16"	80
H5	3.56"	90	3.56"	90	4.312"	110	4.312"	110
O	6.5"	165	6.5"	165	8.25"	210	8.25"	210
R	3.62	92	3.62	92	5.0"	127	5.0"	127
C	0.82"	21	1.0"	25	1.06"	27	1.25"	32
C1	0.062"	1.6	0.25"	6	0.06"	1.6	0.25"	6
BH	0.75"	19	0.75"	19	0.88"	22	0.88"	22
BC	5.0"	127	5.0"	127	6.62"	168	6.62"	168

Turbine Fuel Shut Off Valve - Model 4420E

Maintenance and Service Parts

Over time, exposure to foreign chemicals and particulate matter as well as prolonged operation at extreme conditions may reduce the effectiveness of the valve. At such time, AMOT Turbine Fuel Shut Off Valves can be restored to original performance simply by installing an AMOT turbine fuel shut off valve service kit. Service kits include all new seals and seal components required for normal maintenance.

All seats and seals should be checked annually for leakage and hardening, and replaced if necessary.

Each time the spool (14) is removed from the valve it is recommended that the PTFE seals (14A) (14B) (14C) be replaced. Minor damage or the smallest of cuts to these seals will cause leakage. Replacement of the PTFE seals requires disassembly of the valve spool for which AMOT uses specialized tooling. If preferred this can be done by AMOT, for contact details refer to page 12.

How to order service kits

Service kits are available with seals and other parts required to service the valve. Order service kits by the service kit model number, which is identified by the valve size and type code from the AMOT valve part number.

Service kit model number structure

1) Identify the valve size and type code, located in the Valve size and type (B) section of the AMOT valve part number.

All PTFE seals must be replaced every time that the spool is dismantled, and it is recommended that all O-rings are replaced also. It is recommended that all O-rings be replaced when the valve is dismantled.

AMOT designs and tests all its products to ensure that high quality standards are met. For good product life, carefully follow AMOT's installation and maintenance instructions; failure to do so could result in damage to the equipment being protected or controlled.

Refer to the AMOT valve part number that is printed on the valve nameplate and the AMOT valve part number structure on page 7.

2) Use that value in the service kit identification table below to identify the proper service kit required to service your valve.

Service kit identification							
	Valve size and type (B) ¹					Customer special requirements (G) ²	Service kit model number
	A,B					-AA or -***	10339X001
	C,D						10339X002
Examples							
	Valve part number					Service kit model number	
4420E	A	H	4	F	03	-AA	10339X001
4420E	C	K	4	Q	13	-CZF	10339X002

NOTES:

¹ If your valve size and type code does not correspond with the given values, please contact the facility to confirm your valve size and type code.

² Letters or numbers in the Customer special requirements (G) section of the AMOT valve part number indicate the unit is built to special requirements and some of the other code numbers may not be valid. Contact the facility if your Customer special requirements (G) code differs from -AA to verify which service kit is applicable to your specific Model 4420 valve.

Turbine Fuel Shut Off Valve - Model 4420E

Maintenance and Service Parts Continued

Service parts (refer to diagrams on page 11)

Service kit parts		
Ref no.	Qty.	Description
3	1	Vent cover seal
6	1	Lower cylinder seal
7	1	Upper cylinder seal
11	1	Outer piston seal
12	1	Inner piston seal
14A	1	Upper PTFE Seal
14B	1	Middle PTFE Seal
14C	1	Lower PTFE Seal
14D	1	Outer upper spool seal
14E	1	Inner upper spool seal
14F	1	Lower spool seal
14G	1	Upper middle spool seal
14H	1	Lower middle spool seal
15	1	Upper spool seal
16	1	Upper spool back-up ring
18	1	Inner sleeve seal
19	1	Inner sleeve back-up ring
20	1	Outer sleeve seal
21	1	Outer sleeve back-up ring
34	4	Seal
AP	1	Krytox GPL206 grease, 2 oz tube

Turbine Fuel Shut Off Valve - Model 4420E

Maintenance and Service Parts Continued

Service parts continued

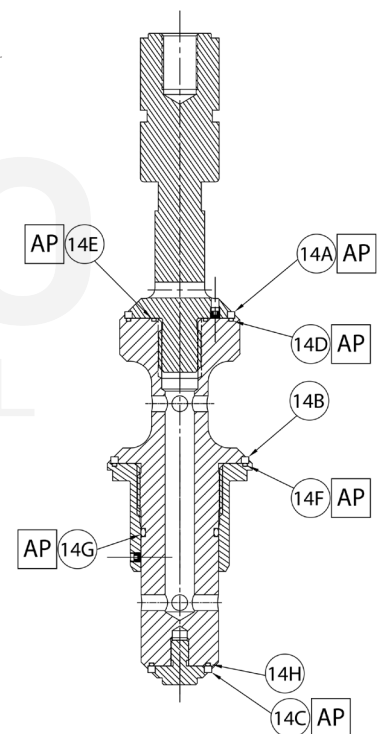
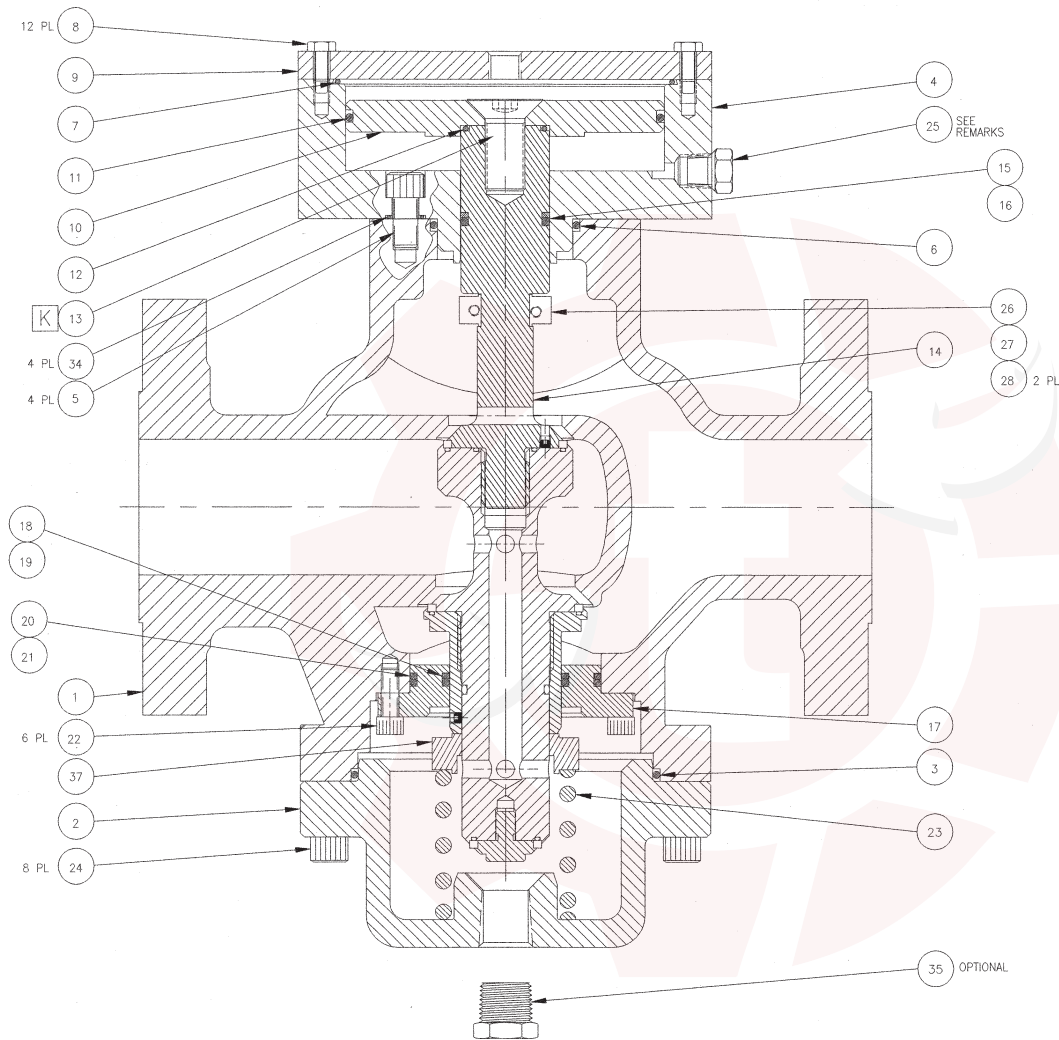

DETAIL A REF